

SINTEK

| NPS | d | H | L |
|--------|------|-----|-----|
| 1/4" | 10 | 38 | 63 |
| 3/8" | 10 | 38 | 63 |
| 1/2" | 15.5 | 43 | 63 |
| 3/4" | 20 | 45 | 75 |
| 1" | 23.5 | 49 | 85 |
| 1 1/4" | 30 | 56 | 100 |
| 1 1/2" | 37 | 64 | 115 |
| 2" | 46 | 71 | 135 |
| 2 1/2" | 64 | 91 | 165 |
| 3" | 74.5 | 103 | 191 |
| 4" | 96 | 138 | 238 |

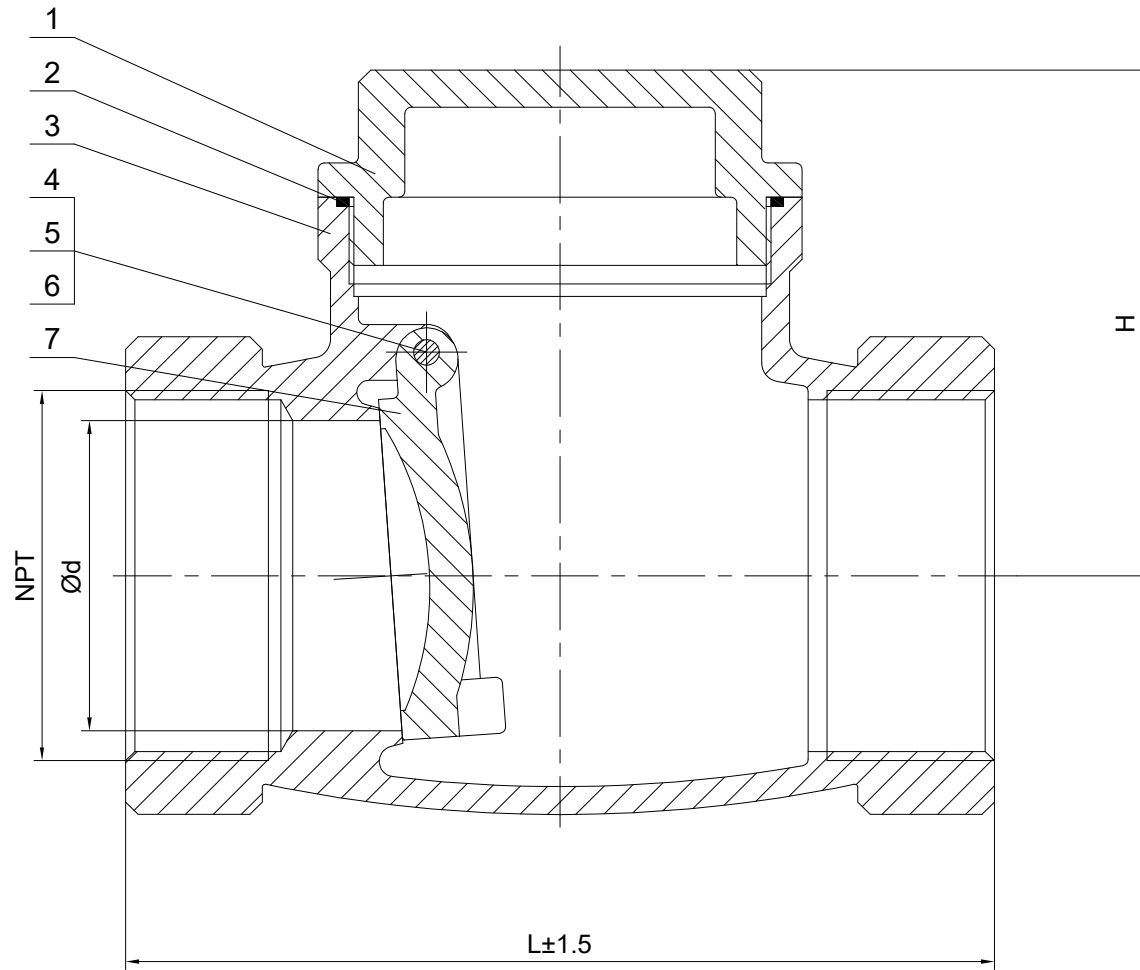

| No. | Part name | Material |
|-----|------------|---------------|
| 7 | Disc | A351 CF8/CF8M |
| 6 | Gasket | PTFE |
| 5 | Bolt | A193 B8 |
| 4 | Hanger Pin | SS304 |
| 3 | Body | A351 CF8/CF8M |
| 2 | Gasket | PTFE |
| 1 | Cap | A351 CF8/CF8M |

| | |
|--------------------------|-------------------------|
| Swing Check Valve 200WOG | |
| Design and manufacture | ASME B16.34 |
| Thread end | NPT |
| Face-to-face | MANUFACTURER'S STANDARD |
| Inspection and test | API 598 |

| | | | |
|----------|--|-----------|--|
| SINTEK | | | |
| DRAWING: | | AUDITING: | |
| APPROVE: | | DATE: | |