

SETE Series

Unidirectional seal Knife Gate Valve



Features:

- # Unidirectional sealing
- # TPC Body design
- # Full port design
- # Mixed with a variety of materials packing

- Model:** SETE
- Working Pressure:** DN50-DN100 16bar
 DN125-DN200 14bar
 DN250-DN300 12Bar
 DN350-DN400 10bar
 DN450-DN550 8bar
 DN600-DN650 5bar
 DN700-DN750 4bar
 DN800-DN900 3bar
 DN1000-DN1400 2bar
- Design Standard:** MSS SP-81
- Flange Standard:** DIN PN10,PN16,150LB ,JIS 10K,TABLE E/D
- Face to Face:** MSS SP-81
- Testing Standard:** API-598
- Transmission:** manual, electric, pneumatic, hydraulic, sprocket, electro-hydraulic, gear
- Main material:** WCB,CF3M,CF8M,CF8
- Wedge material:** SS316L,SS304
- Sealing material:** NBR,EPDM,FKM,Metal
- Packing:** Aramid fiber,high-water-based rubber packing graphite wheel
- Applicable medium:** for pulp, cement slurry, gold ore powder,coal slurry, pulp, chemical treatment of sewage, sedimentation tanks, asphalt,acid and other liquids and other media.

Product Description:

SETE Series Knife gate valve is with replaceable rubber seal knife gate structure, its sealing principle is mainly by closely connection between gate and rubber seals. Its main characters is that the rubber sealing ring is set in seat groove and is locked by metal seat, which will prevent rubber seal off when opening and closing the valve. If the seal is broken, you can remove the metal seat and replace the rubber seal, which will greatly improve valve working efficiency. This valve is a cost-effective, high-performance products. The series of knife gate valve can be equipped with pneumatic actuators, in order to meet the requirements of different industrial and mining use.

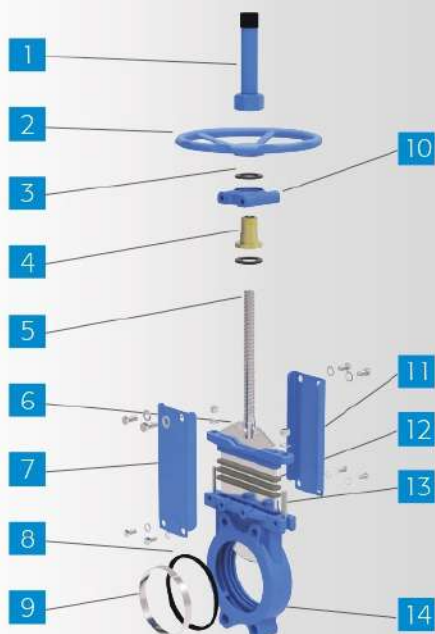

Code	Name	Material	QTY
1	Handle Cover	Q235+Painting	1
2*	Hand Wheel	GGG40	1
3	Bearing	ZChSnSb10-6	2
4	Stem Nut	Brass	1
5	Stem	2Cr13/SS304/SS316	1
6	Disc	SS304/SS316/F55/2205	1
7	Yoke	Q235	1
8	Seat	EPDM/NBR/PTFE/Metal	1
9	Seat Cover	SS304/SS316	1
10	Yoke Head	GGG40	1
11	Packing Gland	WCB/CF8	1
12	Packing	Aramid PTFE	3-5
13	Bolt	Fe+Zn With Painting/SS304	N
14	Body	WCB/GGG40/CF8/CF8M	1

*electric, pneumatic, hydraulic, sprocket, electro-hydraulic, gear **available**

Dimension

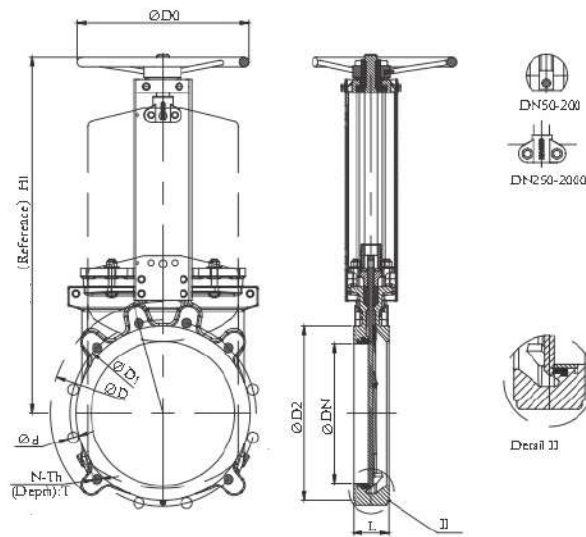

unit:mm

DIN2632 PN10									ANSI 150LB								
DN	L	D	D1	D2	D0	N-Th	d	H1	DN	L	D	D1	D2	D0	N-Th	d	H1
50	48	165	125	99	180	4-M16	Ø18	260	2"	48	152	121	92	180	4-5/8"	Ø19	260
65	48	185	145	118	200	4-M16	Ø18	292	2-1/2"	48	178	140	105	200	4-5/8"	Ø19	292
80	51	200	160	132	200	8-M16	Ø18	320	3"	51	191	153	127	200	4-5/8"	Ø19	320
100	51	220	180	156	240	8-M16	Ø18	358	4"	51	229	191	157	240	8-5/8"	Ø19	358
125	57	250	210	184	260	8-M16	Ø18	395	5"	57	254	216	186	260	8-3/4"	Ø22	395
150	57	285	240	211	280	8-M20	Ø23	450	6"	57	279	242	216	280	8-3/4"	Ø22	450
175	57	305	265	237	280	12-M20	Ø23	504	8"	70	343	299	270	300	8-3/4"	Ø22	532
200	70	340	295	266	300	8-M20	Ø23	532	10"	70	406	362	324	320	12-7/8"	Ø25	670
250	70	395	350	319	320	12-M20	Ø23	670	12"	76	483	432	381	350	12-7/8"	Ø25	758
300	76	445	400	370	350	12-M20	Ø23	758	14"	76	533	476	413	400	12-1"	Ø29	857
350	76	505	460	429	400	16-M20	Ø23	857	16"	89	597	540	470	450	16-1"	Ø29	946
400	89	565	515	480	450	16-M24	Ø27	946									

PN10 Threaded hole and Tapping hole

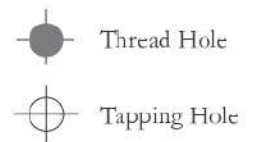
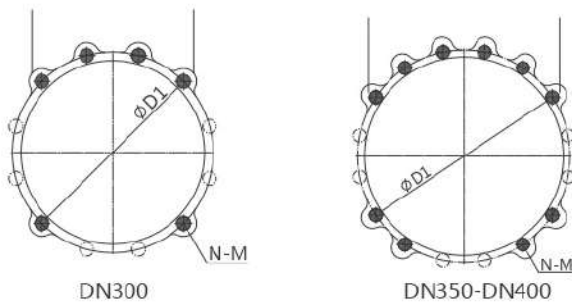
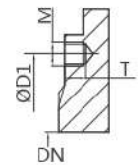
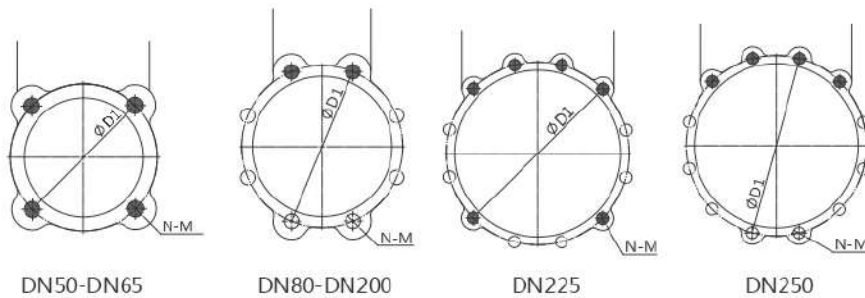

DN	D1	N	PN10		T	Thread Hole	Tapping Hole
			M				
50	125	4	M16		13	2	2
65	145	4	M16		13	2	2
80	160	8	M16		13	2	6
100	180	8	M16		13	2	6
125	210	8	M16		16	2	6
150	240	8	M16		16	2	6
200	295	8	M20		20	2	6
225	310	12	M20		20	6	6
250	350	12	M20		20	4	8
300	400	12	M20		20	6	6
350	460	16	M20		20	10	6
400	515	16	M24		24	10	6

150LB Threaded hole and Tapping hole

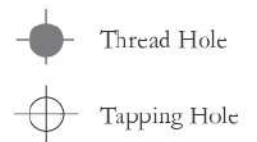
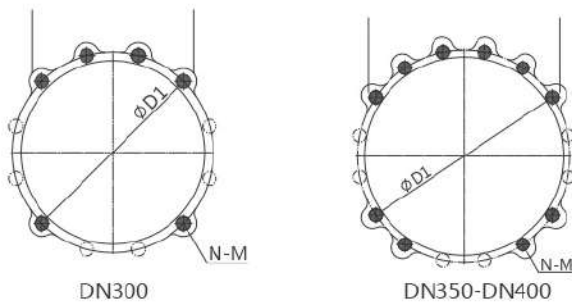
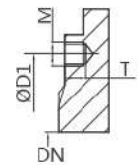
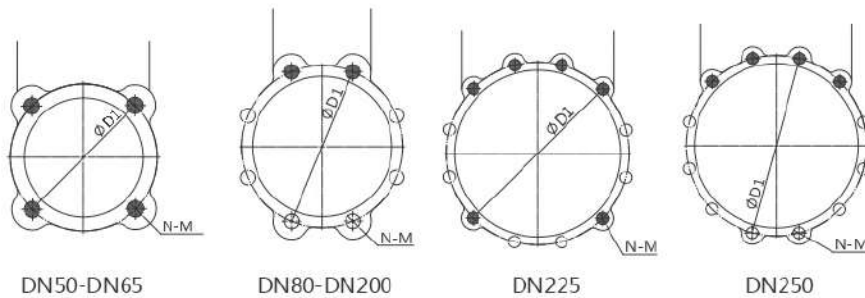

DN	D1	N	ANSI 150LB		T	Thread Hole	Tapping Hole
			M				
2"(DN50)	121	4	M5/8-11		13	2	2
2-1/2"(DN65)	140	4	M5/8-11		13	2	2
3"(DN80)	153	4	M5/8-11		13	2	2
4"(DN100)	191	8	M5/8-11		13	2	6
5"(DN125)	216	8	M3/4-10		16	2	6
6"(DN150)	242	8	M3/4-10		16	2	6
8"(DN200)	299	8	M3/4-10		20	2	6
10"(DN250)	362	12	M7/8-9		20	2	6
12"(DN300)	432	12	M7/8-9		20	6	6
14"(DN350)	476	12	M1-8		20	6	6
16"(DN400)	540	16	M1-8		24	10	6