

SETC Series

Bi-directional Self Sealing Knife Gate Valve

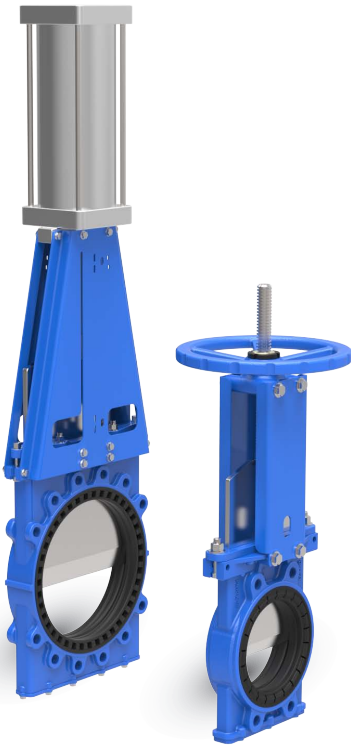

Model:	SETCX	
Working Pressure:	DN50-DN100	16bar
	DN125-DN200	10bar
	DN250-DN400	7bar
	DN450-DN500	5Bar
	DN600-DN700	3bar
	DN800	2bar
Type:	Wafer	
Design Standard:	MSS SP-81	
Flange Standard:	DIN PN10,PN16,150LB ,JIS 10K,TABLE E/D	
Face to Face:	MSS SP-81	
Testing Standard:	API-598	
Operation:	handwheel, electric, pneumatic, hydraulic, sprocket, electro-hydraulic, gear	
Main material:	GGG40	
Wedge material:	SS316L,SS304	
Sealing material:	NR,FKM	
Packing:	Rubber	
Applicable medium:	Applicable to slurry, urban sewage treatment, sugar, powder, paper, medicine, chemicals, food and other fields	

Features:

- # Bi-directional seal
- # additional seat design
- # Self sealing design Suitable for a variety of different conditions
- # 2PC Strong yoke design
- # Cleaning hloe design ,easy for cleaning body Residual medium
- # Mixed with a variety of materials packing

Product Description:

SETC Series Self-sealing knife gate valve is to use two rubber seats on the clip pressed the knife a sealing effect. When the knife is fully open, the two seat seals combined together tightly, the pipeline pressure will make sealing better, while the valve is closed, the gate can be arbitrarily removed convenient maintenance, no need to remove the entire valve repair and does not affect the normal operation of the pipeline. The main characteristics of the valve bore full rubber seal seat, has a strong anti-wear properties and all-pass run off continuity. Suitable for use on those requirements valve wear mining.

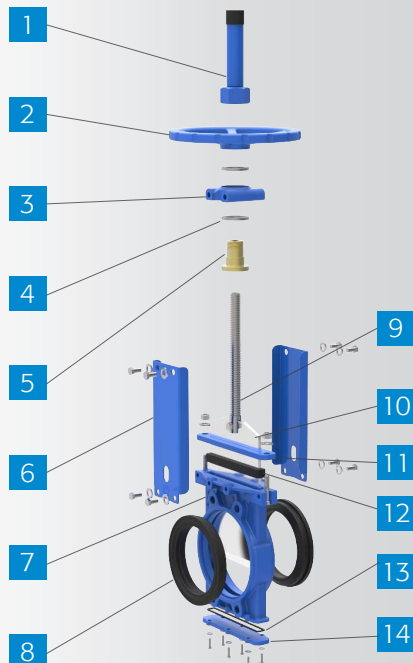

Code	Name	Material	QTY
1	Handle Cover	Steel	1
2	Handle Wheel	GGG40	1
3	Yoke Flange	GGG40	1
4	Bearing	Gcr15	2
5	Nut	Brass	N
6	Yoke	Q235	2
7	Body	GGG40	1
8	Seat	NR+Steel	2
9	Stem	SS420/SS304/SS16	1
10	Bolt&Nut	Fe+Zn(Painting)/SS304	N
11	packing Gland	WCB	1
12	Packing	Rubber	1
13	Packing	Rubber	1
14	Bottom Gland	WCB	1

Dimension

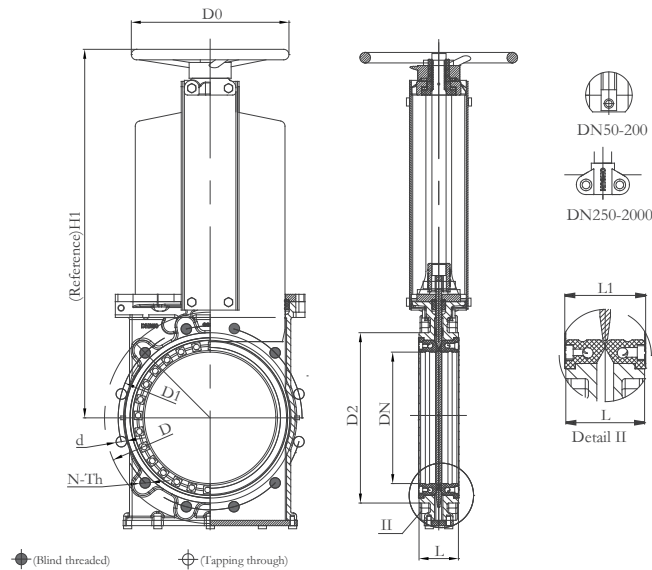

unit:mm

PN10									ANSI 150LB								
DN	L	D	D1	D2	D0	N-Th	d	H1	DN	L	D	D1	D2	D0	N-Th	d	H1
50	53	165	125	99	180	4-M16	Ø18	260	2"	53	152	121	92	180	4-5/8"	Ø19	260
65	53	185	145	118	200	4-M16	Ø18	292	2-1/2"	53	178	140	105	200	4-5/8"	Ø19	292
80	56.5	200	160	132	200	8-M16	Ø18	320	3"	56.5	191	153	127	200	4-5/8"	Ø19	320
100	56.5	220	180	156	240	8-M16	Ø18	358	4"	56.5	229	191	157	240	8-5/8"	Ø19	358
125	63	250	210	184	260	8-M16	Ø18	395	5"	63	254	216	186	260	8-3/4"	Ø22	395
150	62	285	240	211	280	8-M20	Ø23	450	6"	62	279	242	216	280	8-3/4"	Ø22	450
200	76.5	340	295	266	300	8-M20	Ø23	532	8"	76.5	343	299	270	300	8-3/4"	Ø22	532
250	75.5	395	350	319	320	12-M20	Ø23	670	10"	75.5	406	362	324	320	12-7/8"	Ø25	670
300	84	445	400	370	350	12-M20	Ø23	758	12"	84	483	432	381	350	12-7/8"	Ø25	758
350	84	505	460	429	400	16-M20	Ø23	857	14"	84	533	476	413	400	12-1"	Ø29	857
400	99	565	515	480	450	16-M24	Ø27	946	16"	99	597	540	470	450	16-1"	Ø29	946
450	99	615	565	530	500	20-M24	Ø27	1023	18"	99	635	578	533	500	16-1 1/8"	Ø32	1023
500	129	670	620	582	500	20-M24	Ø27	Gear	20"	129	699	635	584	500	20-1 1/8"	Ø32	Gear
550	129	725	680	638	-	20-M27	Ø30	Gear	22"	129	750	692	641	-	20-1 1/4"	Ø35	Gear
600	129	780	725	682	-	20-M27	Ø30	Gear	24"	129	813	750	691	-	20-1 1/4"	Ø35	Gear
700	142	895	840	794	-	24-M27	Ø30	Gear	28"	142	927	864	800	-	28-1 1/4"	Ø35	Gear
800	142	1015	950	901	-	24-M30	Ø33	Gear	32"	142	1060	978	914	-	28-1 1/2"	Ø41	Gear

PN10 Wafer Flange Threaded and Tapping Hole

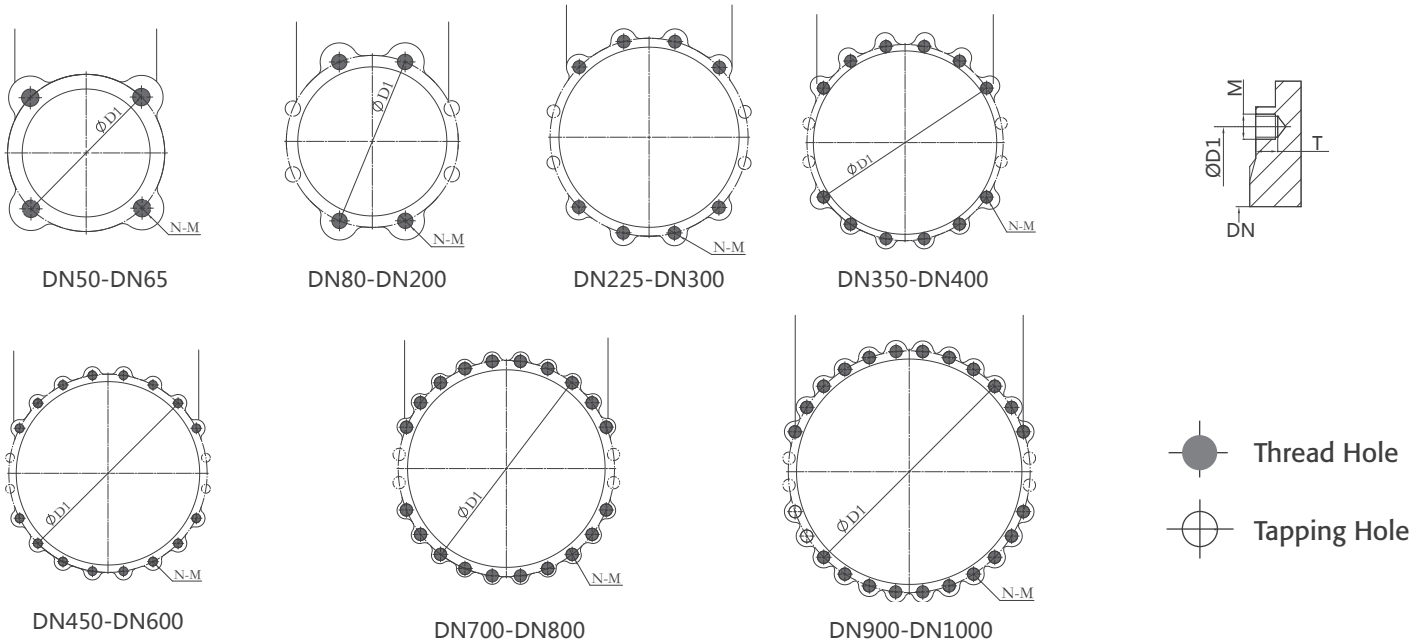

DN	D1	N	PN10		Thread Hole	Tapping Hole
			M	T		
50	125	4	M16	13	2	2
65	145	4	M16	13	2	2
80	160	8	M16	13	2	6
100	180	8	M16	13	2	6
125	210	8	M16	16	2	6
150	240	8	M16	16	2	6
200	295	8	M20	20	2	6
225	310	12	M20	20	4	8
250	350	12	M20	20	4	8
300	400	12	M20	20	4	8
350	460	16	M20	20	8	8
400	515	16	M24	24	8	8
450	565	20	M24	24	16	4
500	620	20	M24	24	16	4
550	680	20	M27	24	16	4
600	725	20	M27	27	16	4
700	840	24	M27	27	20	4
800	950	24	M30	30	20	4
900	1050	28	M30	30	24	4
1000	1160	28	M33	33	24	4

PN10 Wafer Flange Threaded and Tapping Hole

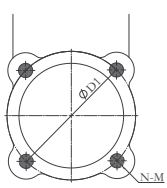

DN50-DN80

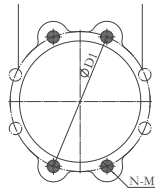

DN100-DN200

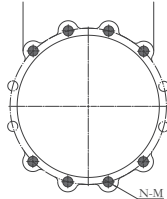

DN250-DN350

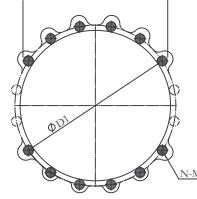

DN400-DN450

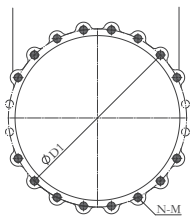
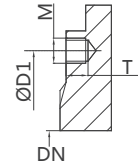

DN500-DN600

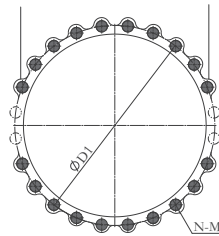

DN650

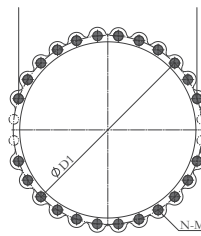

DN700-DN800

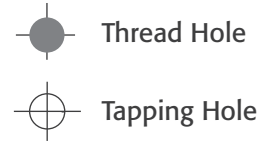

DN	D1	N	ANSI 150LB M	T	Thread Hole	Tapping Hole
2"(DN50)	121	4	M5/8-11	13	4	0
2-1/2"(DN65)	140	4	M5/8-11	13	4	0
3"(DN80)	153	4	M5/8-11	13	4	0
4"(DN100)	191	8	M5/8-11	13	4	4
5"(DN125)	216	8	M3/4-10	16	4	4
6"(DN150)	242	8	M3/4-10	16	4	4
8"(DN200)	299	8	M3/4-10	20	4	4
10"(DN250)	362	12	M7/8-9	20	8	4
12"(DN300)	432	12	M7/8-9	20	8	4
14"(DN350)	476	12	M1-8	20	8	4
16"(DN400)	540	16	M1-8	24	12	4
18"(DN450)	578	16	M1 1/8-7	24	12	4
20"(DN500)	635	20	M1 1/8-7	24	16	4
22"(DN550)	692	20	M1 1/4-7	24	16	4
24"(DN600)	750	20	M1 1/4-7	27	16	4
26"(DN650)	806	24	M1 1/4-7	27	20	4
28"(DN700)	864	28	M1 1/4-7	27	24	4
30"(DN750)	914	28	M1 1/4-7	27	24	4
32"(DN800)	978	28	M1 1/2-6	30	24	4