

Installation guide

Externally operated valve

Type AV210 - Repair kit

042R9316

042R9316

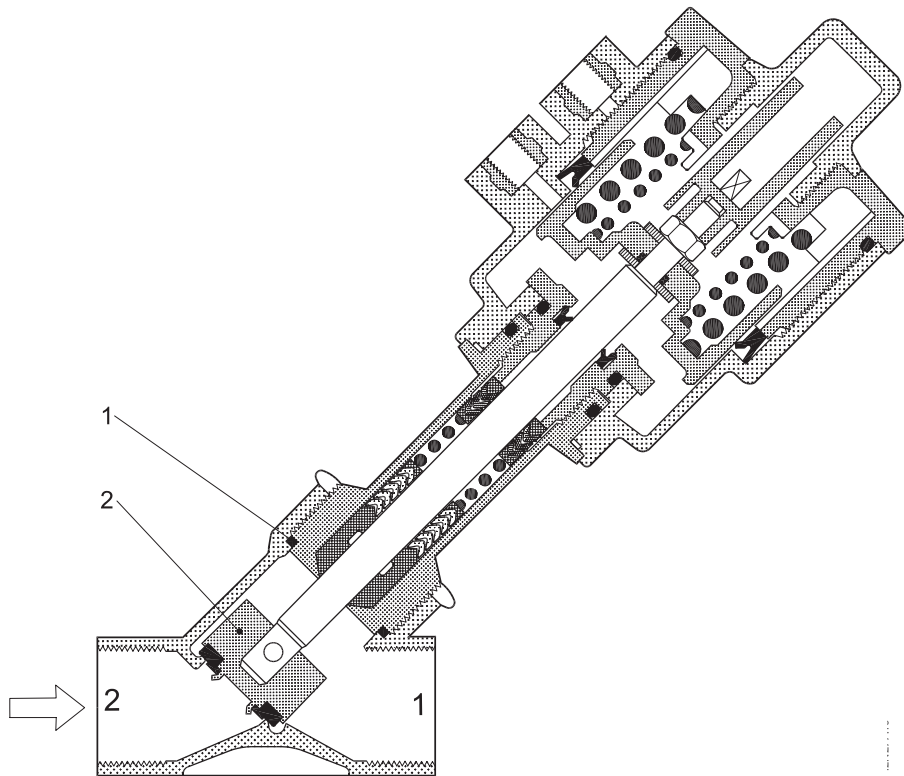

The repair kit contains :

1. Two gaskets (1)
(On actuator size 40 (diameter control head) only one gasket included).
2. One complete valve plate unit (plug and pin) (2).

Note: One gasket is for bronze, and one is for stainless steel.

Tools needed:

- Vice
- Adjustable wrench
- Hammer
- Mandrel
- Chisel

1

1. Fix the valve.
2. Remove sleeve / control top from the valve body.
3. Replace the gaskets.

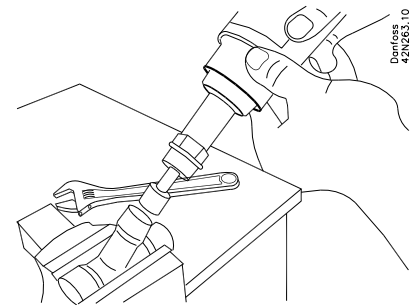
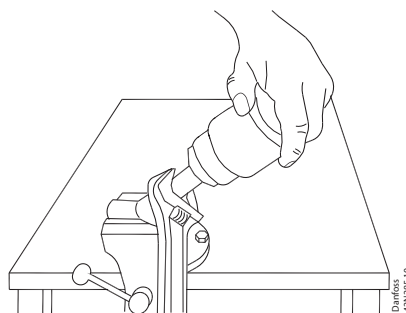

2

1. Fix the plug.
2. Remove the pin.

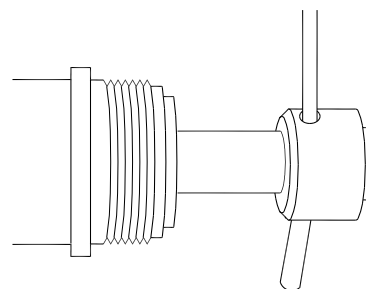
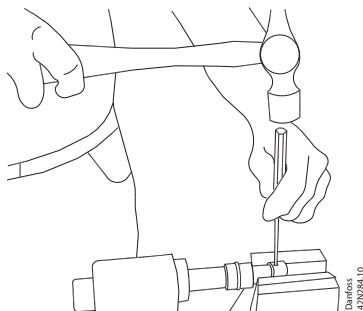

3

1. Replace the plug and pin.
2. Mark a cross over the hole on the plug with a hammer and a chisel, to prevent the pin to pass through the plug once the new pin is fitted.

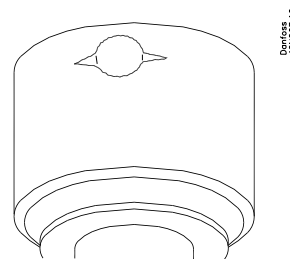
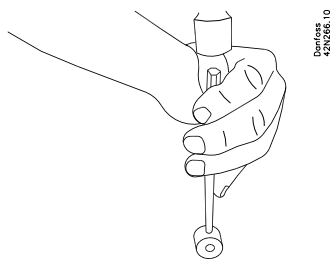

4

1. Fix the plug on piston.
2. Fit the pin through the unmarked pin hole.

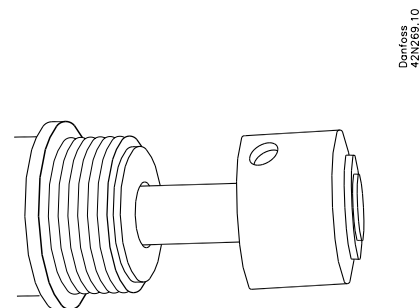
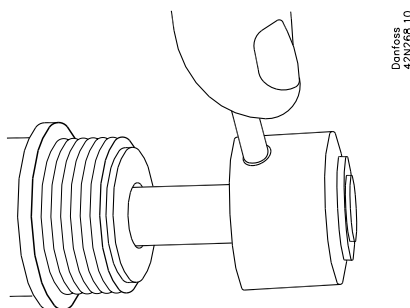

5

1. Mark a cross over the unmarked hole with a hammer and a chisel to fix the pin in plug.

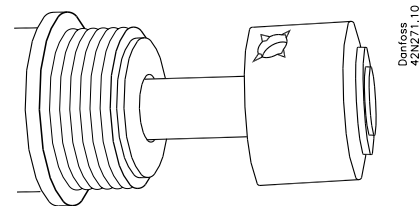
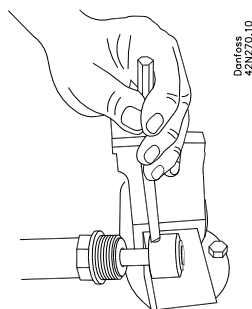

6

1. Assemble the valve in reverse order.

