

Technical brochure

Pressure controls, differential pressure controls and temperature controls, Type RT-E



The RT-E series consist of pressure and differential pressure switches as well as temperature switches. The units are designated for industrial refrigeration and general industrial application in explosive zones acc. to 94/9/EC, ATEX directive, explosive zone 1, for surface equipment, category 2.

It includes usage in refrigeration systems with ammonia, hydrocarbons and other applications where presence of flammable gases, vapours and mists are likely to occur.

RT-E pressure and temperature switches for use in explosive zones incorporate SPDT changeover switch where contact position depends on pressure or temperature value of the system.

Features

- Designed for use in explosive zone 1
- Waterproof versions, enclosure IP66
- Stainless steel frame
- Metalized front cover without window
- Gold plated contacts

Approvals



China Compulsory Certificate, CCC

CE marked, according to EN 60947-4/-5
 CE marked acc. to PED 97/23/EC category IV,
 safety equipment: RTE6AEW, RTE6AEB, RTE6AES

Technical data

*Enclosure**
 IP66 or IP54 (version with external manual reset)

Contact material
 Gold plated AgCdO

Ambient temperature
 -20°C to 65°C

Contact load
 Must be used with reliable means of limiting voltage and current to prevent sparks between contact surfaces. This could be zener diodes or EX barriers.

Cable entry
 2 x Pg 13.5
 Cable diameter: 6 to 14 mm

Contact system
 Single-pole changeovers switch (SPDT)

* IP degree can only be obtained on enclosure without fractures/ damages. RT-E must be protected against unintended impacts.

Ordering

Pressure controls

Type	Range [bar]	Differential [bar]	Max. working pressure [bar]	Reset	Code no.	
					Connection type	
					G 3/8A + welded nipple Ø6.5/10 mm	G 3/8A
RT 112E	0.1 to 1.1	0.07 to 0.16	7	Auto		017-518566
RT 113E	0 to 0.3	0.01 to 0.05	0.4	Auto		017-519566
RT 1AE	-0.8 to 5	0.5 to 1.6	22	Auto	017-500966	
RT116E	1 to 10	0.3 to 1.3	22	Auto		017-520166
RT 5E	4 to 17	1.2 to 4	22	Auto		017-525266
RT6AEW	5 to 25	fixed 3	34 ¹⁾	Auto	017-513866	
RT6AEB	10 to 28	fixed 1.5	34 ¹⁾	Man.	017-513466	
RT6AES	10 to 28	fixed 1.5	34 ¹⁾	Man.	017-502166	
RT117E	10 to 30	1 to 4	42	Auto		017-529866

¹⁾ Max. working pressure acc. to PED is limited to 28 bar

Differential pressure controls

Type	Code no.	Regulating range [bar]	Differential [bar]	Operating range for LP bellows [bar]	Max. working pressure [bar]	Pressure connection
RT260AE	017D003666	0.5 to 4	fixed 0.3	-1 to 18	22	G 3/8A + welded nipple Ø6.5/10mm
RT262AE	017D003066	0.1 to 1.5	fixed 0.1	-1 to 9	11	

Temperature controls

Type	Code no.	Range [°C]	Differential		Max. sensor temperature [°C]	Type of charge	Capillary tube length [m]
			at lowest range setting [°C]	at highest range setting [°C]			
RT14E	017-509866	-5 to 30	2 to 8	2 to 10	150	B	2
RT101E	017-512666	25 to 90	2.4 to 10	3.5 to 20	300	B	2
RT107E	017-515366	70 to 150	6 to 25	1.8 to 8	215	C	2
RT123E	017-521666	150 to 250	6.5 to 30	1.8 to 9	300	C	2

Types of charge:
 B - Adsorption charge
 C - Partial charge

Sensor pockets of RT-E temperature controls	RT14E, RT107E, RT123E..... RT101E.....	Brass: 017-437066 18/8 steel: 017-436966 Brass: 017-437066 17/8 steel: 017-436966
---	---	--

Safety requirements

RT-E pressure, differential pressure and temperature controls comply with the requirements for explosive atmosphere (947/23/EC), acc. to ATEX, zone 1. Only apparatus designed, constructed and released by Danfoss must be used for application concerned. Danfoss can accept no responsibility in case of alterations made on the switches or the use of them against the Danfoss instructions. Original Danfoss spare parts approved for use in explosive atmosphere can only be used.

The application covers systems that must be located within the EU or EFTA and comply with the existing EU legislation, such as Pressure Equipment Directive (PED) (97/23/EC), the directive concerning potential explosive atmosphere (ATEX) (94/9/EC), and other relative EU standards. The system where RT-E is mounted must always comply with local directives, legislation or any other regulation applying in the area of installation. The Danfoss products comply with the requirements of ATEX directive, but Danfoss takes no responsibility for the classification of explosive zone.

Electrical connection

The RT-E pressure control placed in explosive zone must always be wired through reliable zener barrier, placed outside ex-zone, to ensure insufficient energy supply to cause the ignition of surrounding atmosphere by an electrical spark or the heating of components of circuitry.

Cables and cable entries approved for the application must be used and can not be in contact with sharp edges. Cables must be connected with adequate stress relief that way that pulling forces can not be carried through the cable to the terminal.

The equipment to be used for electrical load limiting must always be approved for use in the zone concerned.

Note: A particular system can be classified in different zones, for different parts of the system.

Intrinsic safety protection method

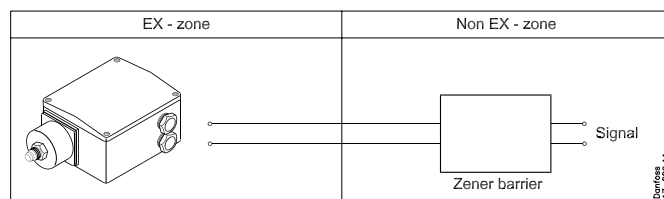

Electrical data for intrinsically safe specification (for all RTE types):
 U_i : 29 V
 I_i : 0.5 A
 P_i : 1 W
 C_i : 0.5 nF
 L_i : 0.2 μH

Installation and maintenance

Only authorised persons, who are certified in installing and maintaining the systems may do the installation, maintenance and change of the switch. In the event of strong pulsation in the system, bellows must be protected against fatigue failure by use of damping coil.

The cycle frequency of the RT-E switch must be kept as low as possible. The vibration level must be kept as low as possible. Any overload of the RT-E switch must be prevented. Overloaded or damaged apparatus must be exchanged.

Design and function

Pressure controls

RT-E controls are similar to non-explosive version of RT. Main design changes include stainless steel frame and metalised front cover to keep surface resistance below 1 Gohm. By turning setting knob (5) the main spring (12) can be set to balance the pressure in the bellows.

A rise in pressure compresses the bellows and moves the main spindle (15) upwards until spring and bellows pressure are in equilibrium. The main spindle (15) is fitted with the guide bush (17) and differential pressure setting nut that together transfer the main spindle movement to the switch (16).

RTE6AEW/B/S has double fail-safe bellows: outer and regulating (inner bellows).

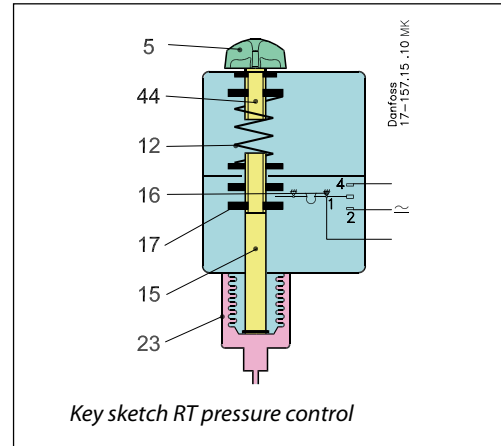

Differential pressure controls

An RT-E differential pressure control contains single-pole changeover switch that makes or breaks depending on pressure differential between two counteracting bellows elements (LP and HP).

The bellows (4) and (24) are respectively connected to lower pressure port and higher pressure port. The main spring (12) can be set for different differential pressure by the setting disc (5). If the differential pressure between higher and lower pressure falls, the spindle (15) moves downwards and via the upper guide bush (17) actuates the switch contact arm (18). The reverse action occurs if the differential pressure rises.

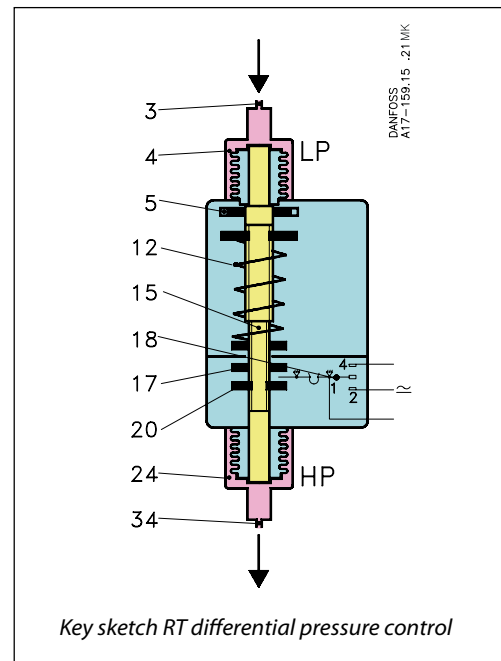

Temperature controls

The thermostatic element consists of sensor (29), capillary tube (28) and bellows element (23). Charge in the element reacts to temperature variations and increases the pressure in the bellows when temperature rises. By turning the setting knob (5) the main spring (12) can be set to balance the pressure in the element. A rise in temperature of the sensor compresses the bellows and moves the main spindle (15) upwards until spring force and element pressure are in equilibrium. Such movement is transferred to the switch (16) and causes its on or off action.

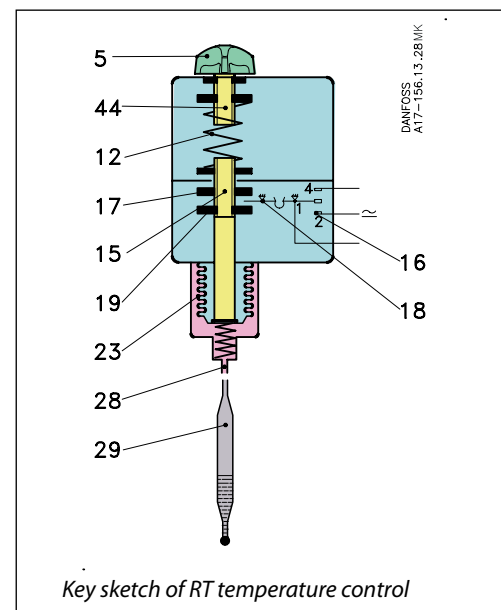

Settings

The range is set by using setting knob (5). Tools must be used to set switches fitted with seal cap. To read the range scale front cover must be removed.

On the units with adjustable differential, differential disc (19) must be set after removing front cover.

For proper adjustment differential roller must be used.

Detailed information can be found in RT data sheets, non-explosive version.

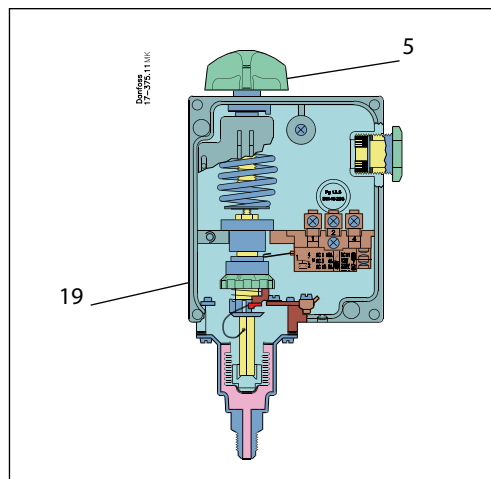

Dimensions

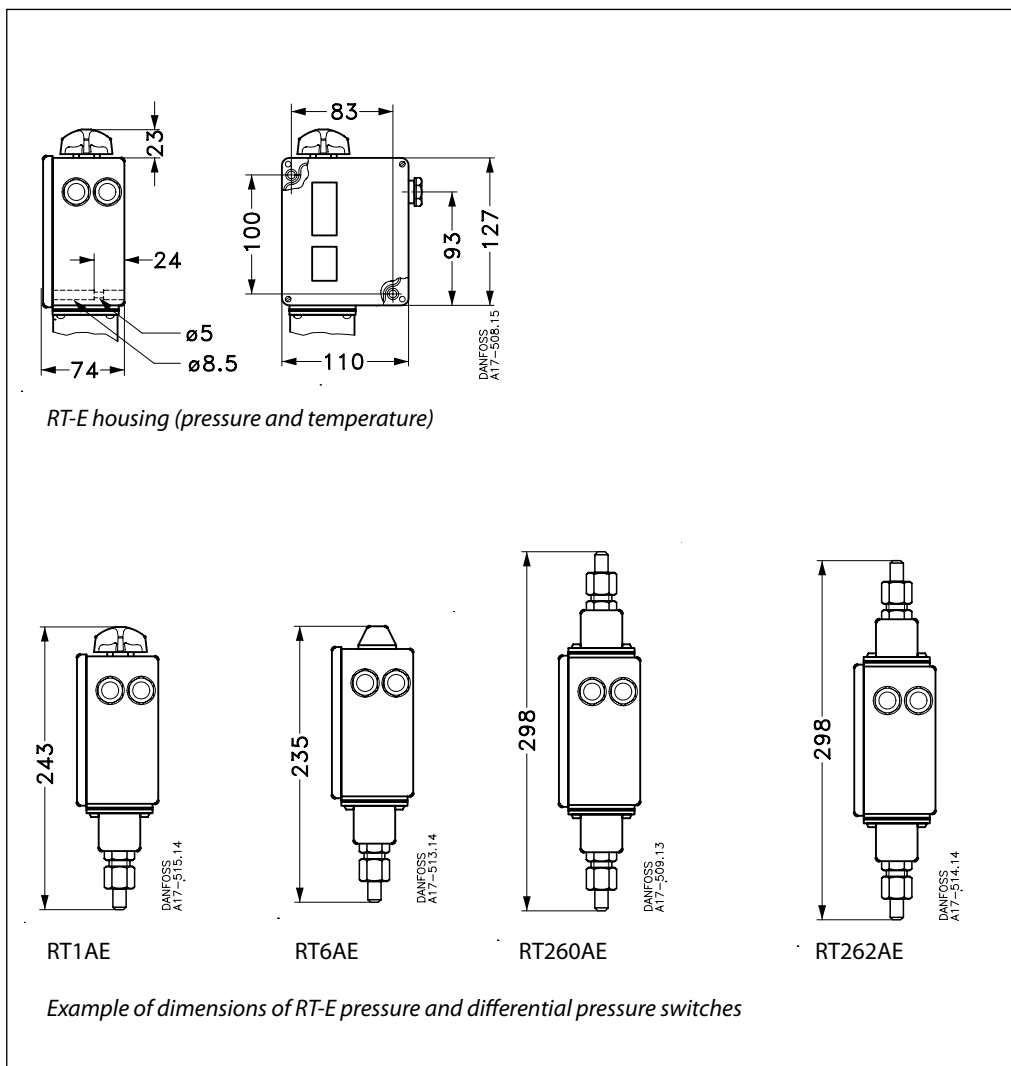

Danfoss can accept no responsibility for possible errors in catalogues, brochures and other printed material. Danfoss reserves the right to alter its products without notice. This also applies to products already on order provided that such alterations can be made without consequential changes being necessary in specifications already agreed. All trademarks in this material are property of the respective companies. Danfoss and the Danfoss logotype are trademarks of Danfoss A/S. All rights reserved.